

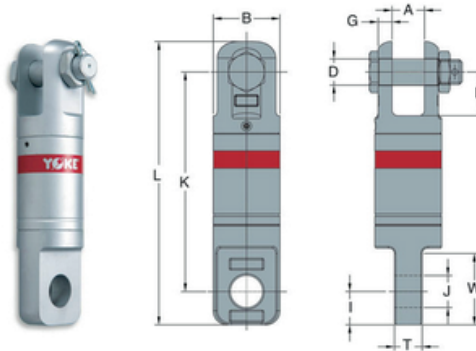

### Yoke Jaw + Eye Angular Swivel

- Yoke Angular Swivels are manufactured using the highest grade of material available.
- They are zinc plated for corrosion resistance and longer life. Angular Swivels are designed for low starting torque and high rotation speed, they are manufactured with grease fittings for superior performance.
- All Angular Swivels are 100% magnaflux crack detected. Designed with a safety factor 5:1



### SPECIFICATIONS - Metric

Part Code	Wire Line Size mm	WLL tonnes	A mm	B mm	D mm	G mm	H mm	I mm	J mm	K mm	L mm	T mm	W mm	Mass kg
8-304-0075	6	0.75	15	32	10	6	22	18	19	103	134	12	37	0.5
8-304-015	10	1.5	18	40	13	7	26	22	23	115	156	15	43	0.9
8-304-03	13	3	23	51	19	10	32	28	27	158	211	20	51	2.2
8-304-05	16	5	32	64	22	14	37	33	33	205	269	26	59	4.4
8-304-085	19	8.5	40	76	30	14	54	38	37	250	322	32	82	7.4
8-304-10	22	10	42	102	38	25	54	52	44	312	412	42	90	17.5
8-304-15	25	15	48	108	38	25	57	64	54	317	434	49	110	21.6
8-304-25	32	25	62	132	51	30	70	70	66	390	524	60	130	39.7

### SPECIFICATIONS - Imperial

Part Code	Wire Line Size inch	WLL tonnes	A inch	B inch	D inch	G inch	H inch	I inch	J inch	K inch	L inch	T inch	W inch	Mass lbs.
8-304-0075	1/4	0.75	0.60	1.30	0.40	0.20	0.90	0.70	0.80	4.10	5.30	0.50	1.50	1.1
8-304-015	3/8	1.5	0.70	1.60	0.50	0.30	1.00	0.90	0.90	4.50	6.10	0.60	1.70	2.0
8-304-03	1/2	3	0.90	2.00	0.80	0.40	1.30	1.10	1.10	6.20	8.30	0.80	2.00	4.8
8-304-05	5/8	5	1.30	2.50	0.90	0.60	1.50	1.30	1.30	8.10	10.60	1.00	2.30	9.7
8-304-085	3/4	8.5	1.60	3.00	1.20	0.60	2.10	1.50	1.50	9.80	12.70	1.30	3.20	16.3
8-304-10	7/8	10	1.70	4.00	1.50	1.00	2.10	2.00	1.70	12.30	16.20	1.70	3.50	39.0
8-304-15	1	15	1.90	4.30	1.50	1.00	2.20	2.50	2.10	12.50	17.10	1.90	4.30	47.6
8-304-25	1-1/4	25	2.40	5.20	2.00	1.20	2.80	2.80	2.60	15.40	20.60	2.40	5.10	87.3